



STRONG POWERFUL

REMARKABLY PRODUCTIVE. EXTREMELY COMFORTABLE.

CONSTRUCTION MACHINERY



CRAWLER EXCAVATOR **SY305H**

Engine
Isuzu GH-6HK1
Rated power
212kW/ 2000rpm
Bucket capacity
1.7 m³
Operating mass
32265 kg

SANY

SY305H

For challenging tasks, you need a first-class partner

Quality comes from experience. And from new ideas. This is why we combine these two crucial factors at SANY. This is because we are one of the world's leading producers, having sold more than **320 000** excavators in **10 years**. This means that you can always rely on sophisticated products that have been tried and tested in practice. An impressive **5–7%** of our annual turnover is dedicated to research and development. This is why we give you not only our word, but also our extraordinary **five-year warranty** as a guarantee of how powerful and robust our products are.

320 000
EXCAVATORS SOLD IN
10 YEARS

5–7%
TURNOVER FOR RESEARCH
AND DEVELOPMENT

**FOUR-YEAR
WARRANTY***

Quality Changes the World

* Applicable in certain markets, please check with your local dealer.



SY305 HARD FACTS

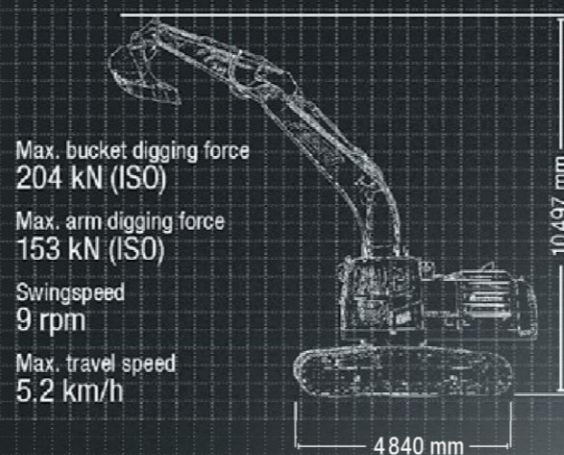

MOVE MORE WITH LESS EFFORT

The SANY SY305 crawler excavator makes no compromises. It works powerfully wherever maximum performance is required for excavation work and in civil engineering. The machine's high-quality technology and robust components form the basis for reliable and quick operation, meaning that the vehicles can be used continually. This prevents downtime and also reduces maintenance and servicing time. You can therefore complete

all of the work at the construction site on time and on budget. Maximum productivity is also the result of the machine's high degree of flexibility. This is not only thanks to the extensive standard features – with two cameras, two auxiliary proportional control circuits and the pre-installed quick-change mechanism – but also the easy changeover of the work tools used and the associated hydraulic settings.

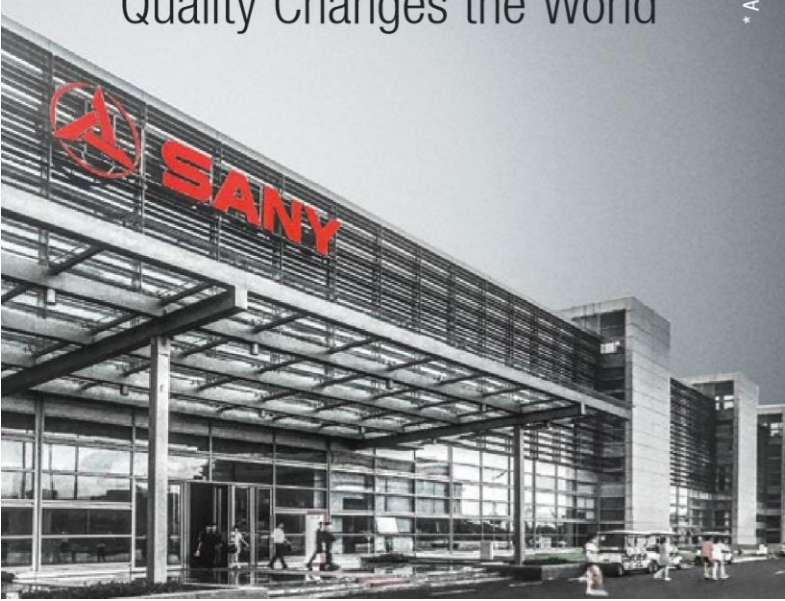

TOP PROPERTIES

ECONOMY

TOP PERFORMANCE WITH MAXIMUM COST-EFFECTIVENESS

The drive unit supplies the necessary power to cover power peaks without any difficulty. Furthermore, the unit not only meets the strict requirements of Stage V emission standards, it is also particularly fuel-efficient and quiet. A reason for this is the fact that the electronically controlled clutch fan only switches on if necessary and therefore operates precisely according to requirements.



SAFETY

Good lighting for good visibility

If it starts to get dark, the machine has eight LED work spotlights which provide the best possible illumination.

The rear and side cameras transmit the images of the surrounding area to the high-resolution monitor as standard. This ensures that the driver always has the best possible view of the working area and travel path.

Another element for improved safety is the machine's maintenance platform. It has an anti-slip surface and non-slip handrail, which ensure a secure grip even in wet conditions.



COMPONENTS

Power in every situation – the powerful ISUZU unit not only stands out thanks to its compact design, but also, above all, its very high degree of efficiency.

DIMENSIONS

Stable foundation – while the machine is one of the heaviest in its class, operators also have optimal visibility to the rear thanks to the flat design.

USER EXPERIENCE

Everything under control – the high-resolution 10" touch display means that the operator has everything in reach – even when wearing gloves. The display offers a clear overview and easy, intuitive menu navigation.



SAFETY

Two eyes are better than one – the rear and side cameras mean that the operator has a view of everything. Moreover, the images from the cameras can either be individually shown on the large display or in combinations.

QUALITY

Lasting quality – the daily working environment at construction sites is tough. To ensure that SANY excavators can withstand these rigours in the long term, they are designed and produced with particular care. Among other elements, this includes incorporating clean piping and precisely positioned welded seams.

ECONOMY

Maximum efficiency or maximum performance – with the SANY SY305C, you have the choice for every application and can select the optimal operating mode for the task you are currently working on. Furthermore, the extensive standard features make the machine a real price-performance champion.

ECONOMY

Quick tool changeovers

The hydraulic quick-coupler-preparation is already included ex-works as standard and is incorporated into the operating concept. In addition, one of the machine's new features makes changing tools even easier and quicker. When changing from hammer to shear hydraulics, the hammer valve is changed by pressing a key on the display.



Absolute reliability – for peace of mind!

SANY's four-year warranty* gives you the assurance that you can fully count on your equipment.

* With participating partners

ECONOMY

Everything in sight and within reach

To enable efficient work at the construction site, you can, for example, save the required working pressures and oil flow for up to five attachment devices for each category. Simply enter the name of the tool in the large, high-resolution 10" touchscreen display and assign the required value to the tool. This makes it quick and easy to change attachment devices on the construction site – enabling significant time and cost savings. In addition, the large touch display allows you to intuitively navigate through the simple menu structure and to monitor all of the important parameters.



USER EXPERIENCE

INNOVATIONS SET THE MACHINE APART

From the first time an operator sits in the new SANY SY305 they know that it offers a first-rate user experience. From first sight, it is apparent that the driver's cab is impressive. Let's take the clear 10" touch display as an example. Its high-resolution screen not only displays a considerable amount of information, it also shows the images from the two cameras. The touch display can also be used for various operating functions, meaning that many of the features are easy to control using just a finger.

Moreover, the seating position of the air-suspension driver's seat with integrated seat heating can be continuously adjusted. The control elements connected to the seat can be used to make any adjustment, further adding to the ergonomics and user experience.



USER EXPERIENCE

Easy to maintain and durable

All of the wear parts for the SANY SY305C have been designed to have a particularly long service life. For instance, the oil and fuel filters have long maintenance intervals and are positioned outside of the engine compartment. We've also made the daily routine check a whole lot easier. The dipstick, air filter and coolant level can be easily checked from the ground.



USER EXPERIENCE

Comfortable workstation

The cab's insulation, which has been further optimised, provides the driver with increased protection from noise and dust. This creates the conditions for more relaxed, fatigue-free working thanks to the quieter and cleaner driver environment. The machine also helps to ensure that snacks and drinks are kept cool even on long, hot days thanks to its automatic air conditioning system, various storage options and the large, chilled compartment behind the driver's seat.



COMPONENTS

The right kind of pressure

The Kawasaki hydraulic system offers a high performance you can rely on. It applies exactly the right hydraulic pressures required for your task. The first and second proportional auxiliary lines are fitted ex-works as standard. Their pressure and power output per litre are individually adjustable. It is also very easy to save these values for each attachment device via the display menu and they can be quickly retrieved at any time.



Our highlights – the added benefits SANY offers you:

- + 10" high-resolution touchscreen display
- + 2 cameras
- + Seat with adjustable control panels
- + 5 different attachment devices can be programmed for each category (name, pressure, oil flow)
- + 2 proportional auxiliary lines as standard
- + Convenient switching of hammer/shear hydraulics

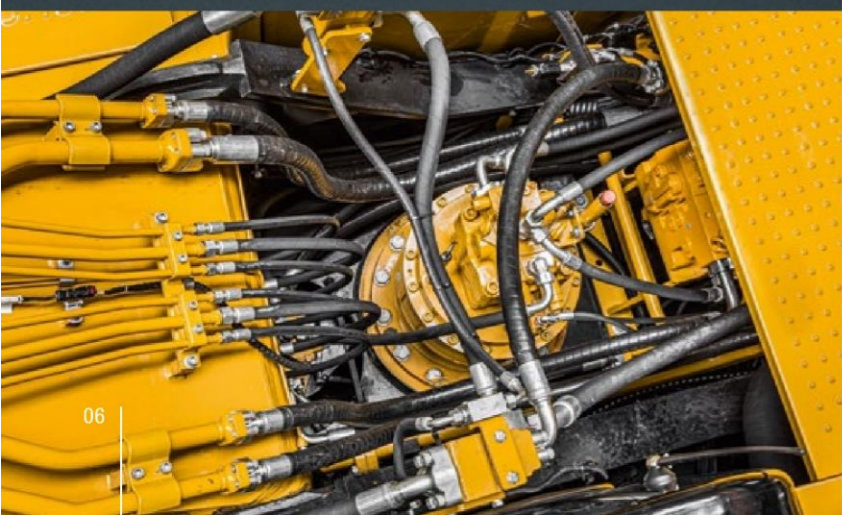

COMPONENTS

RELIABLE AND EFFECTIVE

The drive unit made by ISUZU not only embodies the highest degree of reliability, it also boasts innovative exhaust treatment. In order to comply with Stage V emission standards, the unit operates with a combination of SCR and DPF technology. The fact that the exhaust gas is not recirculated significantly increases efficiency, resulting in maximum productivity with minimal fuel consumption. Moreover, the unit has a more compact design because, among other things, additional cooling units are no longer required. This enables the package space to be kept clear for optimal visibility to the rear.



ENGINE

Model	ISUZU GH-6HK1
Typ	Water-cooled, 6 cylinder, with commonrail and Adblue
Exhaust emissions	Stage V
Rated power	212Kw/ 2000rpm
Max. torque	1 472 Nm / 1 400 rpm
Displacement	8 900 ccm
Batteries	2 × 12 V / 120 Ah

HYDRAULIC SYSTEM

Mainpump	2 x variable piston pump with electronic positive control
Max. oilflow	2 x 280 l/min
Travelmotor	Variable displacement axial piston motor
Swingmotor	Axial-piston motor
Max. oilflow (AUX1)	500 l/min

RELIEF VALVE SETTINGS

Implement circuit	343 bar
Power boost	373 bar
Swing circuit	275 bar
Travel circuit	343 bar
Pilot pressure	39 bar

SERVICE REFILL CAPACITIES

Fuel tank	430 l
Engine coolant	36 l
Engine oil	21 l
Drive (per side)	10,5 l
Adblue	85 l
Hydraulic oil tank	300 l

PERFORMANCE

Swingspeed	9 rpm
Max. travel speed	High 5.2 km/h, slow 3.4 km/h
Max. travel force	245 kN
Gradeability	35°
Bucket capacity	1.7 m³
Groundpressure	0.6 kg/cm²
Bucket digging force ISO	204 kN
Arm digging force ISO	153 kN

UNDER AND UPPER STRUCTURE

Boom length	6 150 mm
Arm length	3 200 mm
Bottomrollers	9
Toprollers	2
Rotation device	Planetary gear reducer driven by an axial piston motor, automatic hydraulic released slewing brake

OPERATING MASS

SY305	32 265 kg
-------	-----------



DIMENSIONS (TRANSPORT)

A Transport length	10 667 mm
B Transport width	*2 990 mm **3 190 mm
C Upperstructure carriage	2 986 mm
D Height over cabin/ROPS	3 280 mm
E Height of Boom – transport	3 470 mm
F Overall length of crawler	4 840 mm
G Tail length	3 315 mm
H Track gauge	*2 390 mm **2 590 mm
I Track height	1 025 mm
J Track pads width	600 mm 700 mm 800 mm
K Min. ground clearance	470 mm
L Counterweight clearance	1 045 mm
M Engine cover height	2 640 mm
N Center distance of tumblers	3 916 mm

*at 600 mm track pads width
**Wide undercarriage with 600 mm track pads width

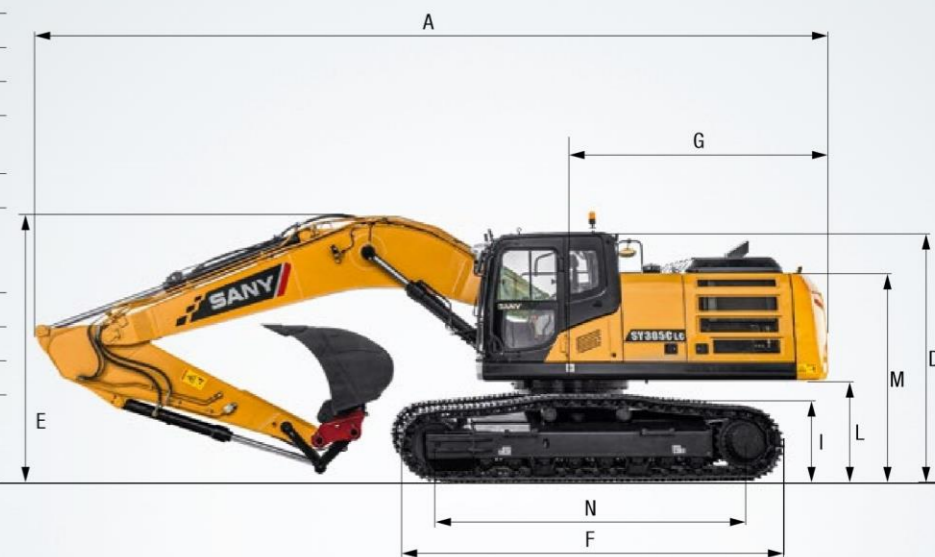

LIFTING CAPACITIES*

Load point height	Radius				Max. digging reach	
	3.0m	4.5m	6.0m	7.5m	Capacity	'''
7.5 m kg					5 706	6 954
6.0 m kg				7 440	5 512	5 308
4.5 m kg			8 777	8 777	7 857	5 460
3.0 m kg	13 301	10 813	10 078	7 211	8 500	5 270
1.5 m kg	15 494	10 106	11 268	6 853	7 696	5 081
Ground kg	16 368	9 767	11 989	6 615	7 544	4 941
-1.5 m kg	12 939	12 939	16 113	9 688	10 261	6 514
-3.0 m kg	20 377	20 377	14 864	9 777	11 298	6 547
-4.5 m kg	16 297	16 297	12 257	10 032	9 079	6 748

*at 3 200 mm undercarriage width

WORKING AREA

A Max. digging reach	10 870 mm
B Max. digging depth	6 815 mm
C Max. digging height	10 497 mm
D Max. dumping height	7 359 mm
E Min. dumping height	2 450 mm
F Max. vertical digging depth	5 800 mm
G Overall height over arm by min. swing radius	8 405 mm
H Min. swing radius	4 000 mm

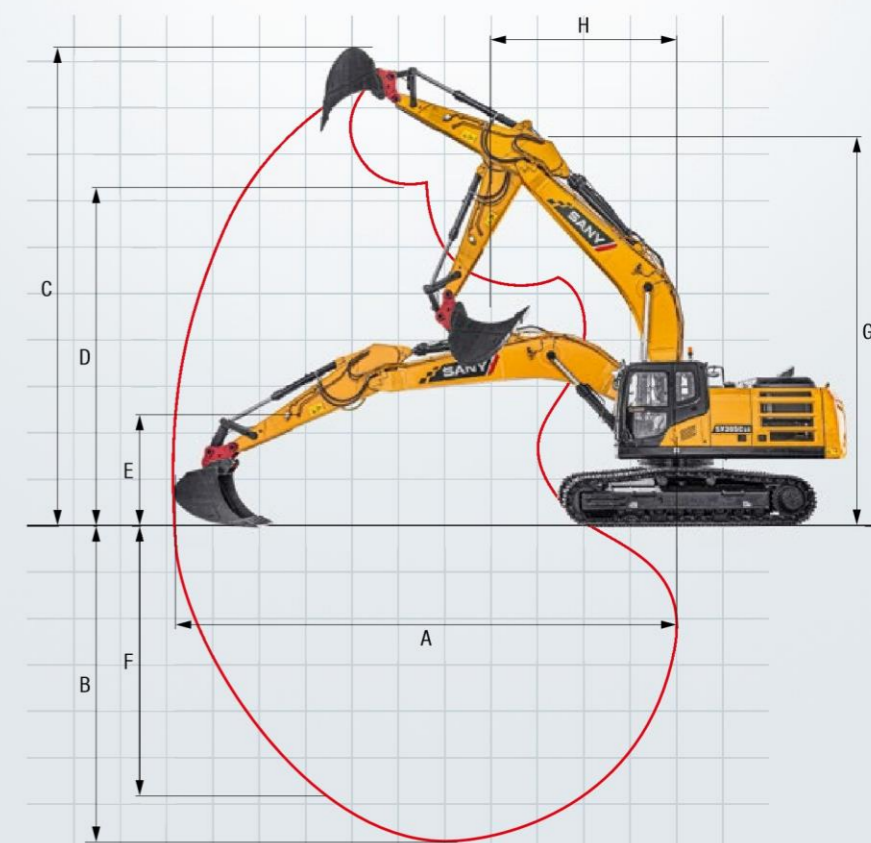

Expect more from your machinery

The SY305 crawler excavator is already fitted with an excellent range of equipment ex-works. It offers maximum comfort in the driver's cab for the greatest possible flexibility for all tasks, as well as maximum efficiency, giving you a competitive edge.



OPERATORS COMFORT / CABINE

Heater	●
Automatic air conditioning C/H*	●
Radio and speaker	●
Armrests (adjustable)	●
Airsuspension seat	●
Heated seat	●
Wiper	●
Sprayer f. wiper	●
AUX 1 on Joystick	●
AUX 2 on Joystick	●
Joysticks independently from seat adjustable	●
Sky light openable	●
10" touchscreen display	●

WORKING EQUIPMENT

Boom and arm load holding valves with overload indicator	●
Double acting circuit for hydraulic quick coupler with piping	●
Breaker&Shear line proportional on Joystick with piping	●
Rotation line proportional on Joystick with piping	●
Flow adjustment for attachments	●
Pressure adjustment for attachments	●

UNDERCARRIAGE

Steel tracks	●
Holes/loops for fixing	●
HD Line	●

Standard equipment ● Special option ●

The standard and special options differ depending on the country in which the crawler excavator is delivered. If you have any questions, please contact your dealer directly.

* The air conditioner contains fluorinated greenhouse gases: Refrigerant type: HFC-134a, Global warming potential: 1 430, Quantity: 0,9 kg, CO₂e: 1,29 t

WORKING LIGHTS

Lights – front (LED)	●
Lights – boom (LED)	●
Lights – platform (LED)	●
Lights – back (LED)	●

ENGINE

Auto idle	●
DPF	●
SCR	●

HYDRAULIC SYSTEM

Swing brake	●
2 speed travel	●
Piping for additional hydraulic function AUX 1	●
Piping for additional hydraulic function AUX 2	●
Fuel filler pump with automatic shut-off	●
Hydr. Pre-pressure operating joysticks	●
Switchover hammer valve in display	●

SAFETY

Battery master switch	●
Travel Alarm	●
Warning beacon	●
Camera	●
Side camera	●
Handrails	●
Lockable fuel cap	●

A SERVICE YOU CAN RELY ON

Just as we do with our excavators, we also demand high quality and reliability of our service products. This underlines our equipment's performance in terms of their durability and their excellent price-performance ratio. After all, maintenance is crucial

for efficiency, cost-effectiveness and safety. Your SANY dealer is happy to help you with a comprehensive range of services to ensure that your machine continues operating efficiently in the long term.

Global Brand, Local Knowledge

Flexible, fast and always there for you

Rapid assistance, tailored advice and a reliable supply of original parts all around New Zealand.



The Vertu Difference

- + Site visits to get your machine back up and running as soon as possible.
- + Significant inventory of SANY genuine and after market parts and attachments.
- + Expert knowledge including SANY trained technicians.
- + If a repair cannot be undertaken on-site or in good time, Vertu will arrange a similar replacement while your machine is repaired under warranty.

Parts supply – quick and reliable

With the purchase of a SANY crawler excavator you have made an investment in the future. Fast availability of spare parts is your guarantee of minimal downtimes and failure times.



Detailed information in black and white

Handbooks and documents are available for all SANY crawler excavators, and these can help you with operation, maintenance, servicing and repairs. These include operating and maintenance instructions and technical specifications.



HIGHLIGHTS SY305H

THE ALL-INCLUSIVE POWERHOUSE

With its extensive equipment, the SY305H offers an impressive price-performance ratio. Everything you need to comfortably use the powerful machine on the construction site is included ex-works.



STABLE FOUNDATION

The SY305H's **efficient weight distribution** and **great stability** means that it cuts a good figure. Furthermore, its **precise balance** ensures that its power can always be used optimally.

EVERYTHING UNDER CONTROL

With the SY305H, you simply need to take a seat and everything is within reach. The **comfortable driver's seat** can be independently adjusted in many directions and gives you the highest degree of **ergonomics** and **operating safety** thanks to the **synchronised controls**.

TWO EYES ARE BETTER THAN ONE

The two **cameras installed as standard** cover the entire working environment. Operators also always have good visibility to the rear thanks to the **low design of the machine's rear**.

POWER IN EVERY SITUATION

Rely on the first-rate performance of the tried-and-tested **6-cylinder Cummins engine**. Its power gives you the certainty of a **high performance** and also ensures **minimal fuel consumption**.

MAXIMUM EFFICIENCY OR MAXIMUM POWER

The two **auxiliary lines are proportionally controlled**. In addition, the pressure and

power output per litre are **individually adjustable** and can be saved for certain tasks and attachment devices. This means that you always have the right **pre-configured hydraulic settings** available for every attachment device.

TECHNICAL HIGHLIGHTS

Rated power	212 kW / 2 000 rpm
Max. torque	1 472 Nm / 1 400 rpm
Max. travel speed	5.2 km/h
Swingspeed	9 rpm
Mainpump	2 x variable-piston-pump with electronic positive control
Max. oilflow	2 x 280 l/min
Engine	ISUZU

Not all products are available in all markets. As part of our continuous improvement process, we reserve the right to modify specifications and designs without giving prior notice. The figures may contain additional options.

Vertu Equipment

Tel: 0800 837 888
www.vertuequipment.co.nz
info@vertuequipment.co.nz

510 Ellerslie-Panmure Highway
 Auckland

SANY

Quality Changes The World